

NOTE: FOLLOW PROPER INSTALLATION GUIDELINES AS PER THE MAGNUMSTONE INSTALLATION MANUAL. ENSURE LOCAL CODES AND GUIDELINES ARE ALWAYS BEING FOLLOWED.

These preliminary details are intended solely to act as an aid when designing a wall. This drawing should not be used for final design or construction. Each site-specific wall should be certified and signed by a registered geotechnical engineer in the State or Province that it is being built. The accuracy and use of the details in this document are the sole responsibility of the user. Global stability analysis has not been performed.

MagnumStone®

26° | No Load

Geogrid Wall Charts

Slope Angle 0°
 Live Load 0 PSF
 Retained Soil 26°
 Foundation 26°
 Reinforced 26°
 Leveling Pad Crushed Gravel

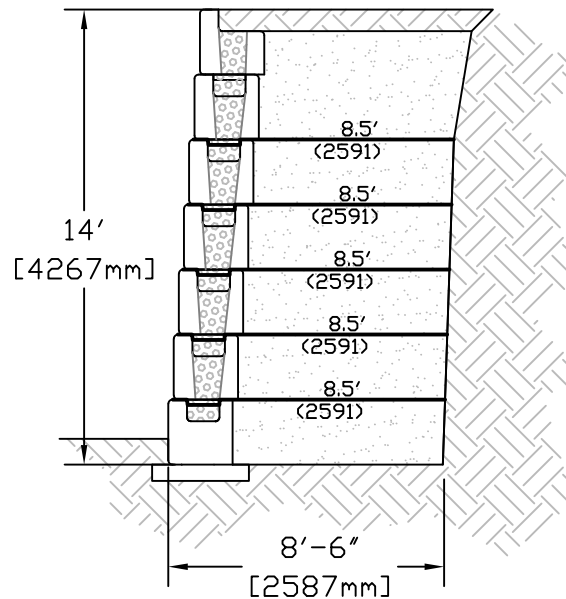
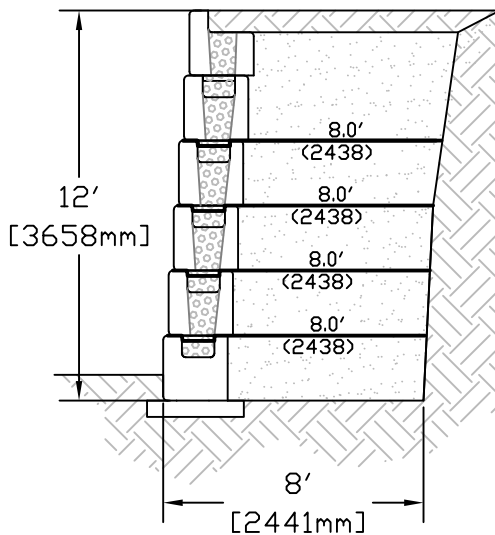
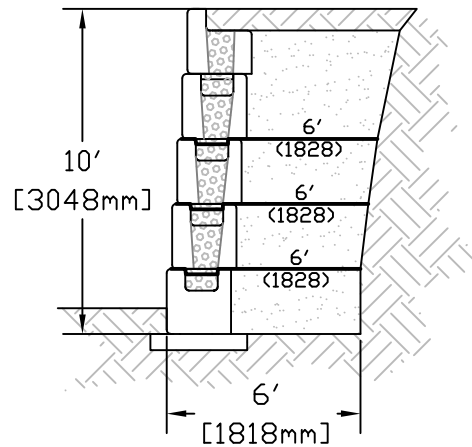
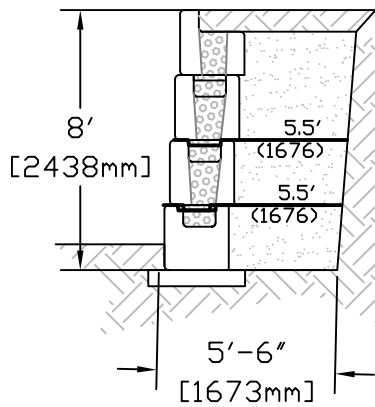
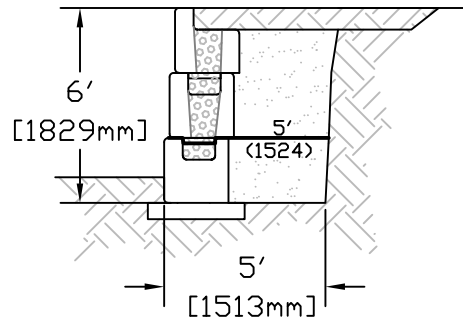

MagnumStone®

28° | No Load

Geogrid Wall Charts

Slope Angle 0°
 Live Load 0 PSF
 Retained Soil 28°
 Foundation 28°
 Reinforced 28°
 Leveling Pad Crushed Gravel

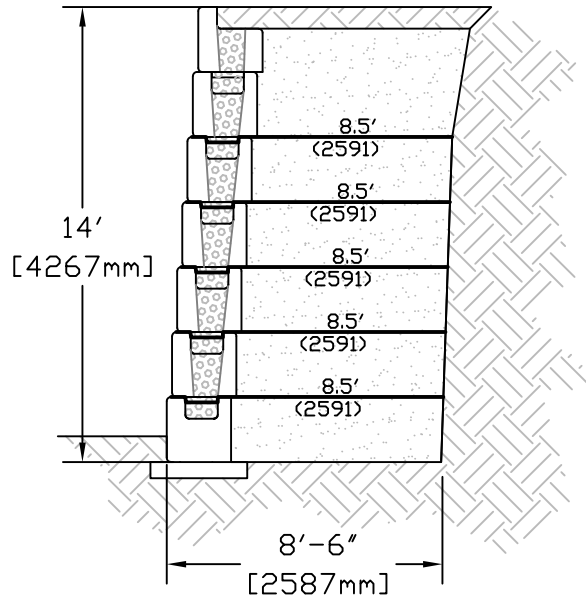
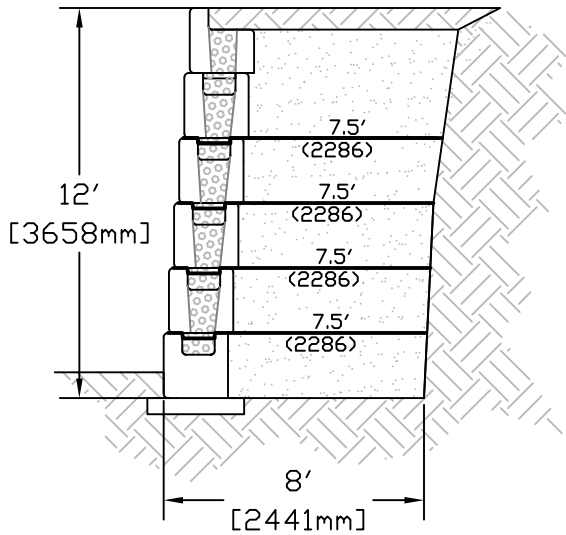
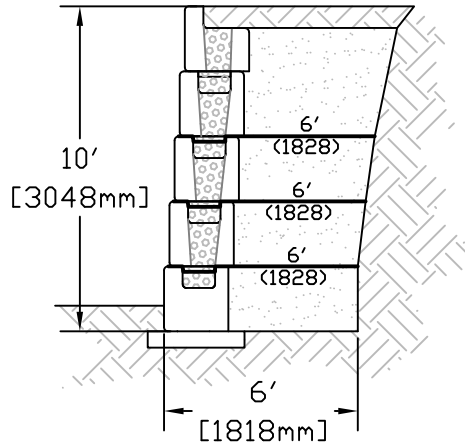
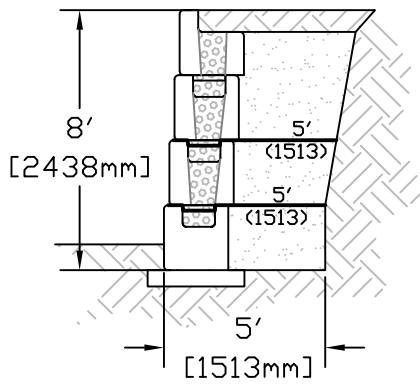
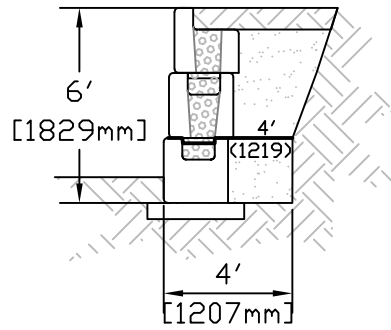

MagnumStone®

30° | No Load

Geogrid Wall Charts

Slope Angle 0°
 Live Load 0 PSF
 Retained Soil 30°
 Foundation 30°
 Reinforced 30°
 Leveling Pad Crushed Gravel

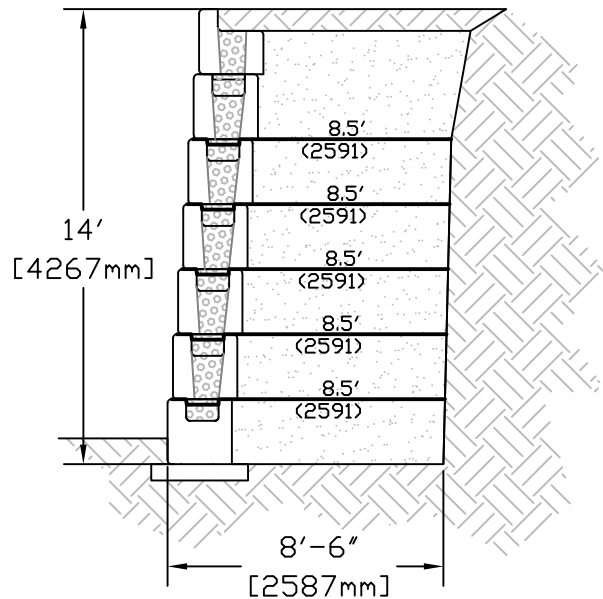
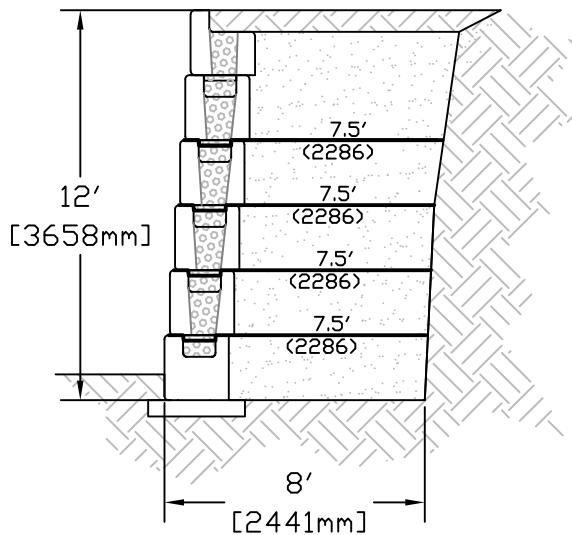
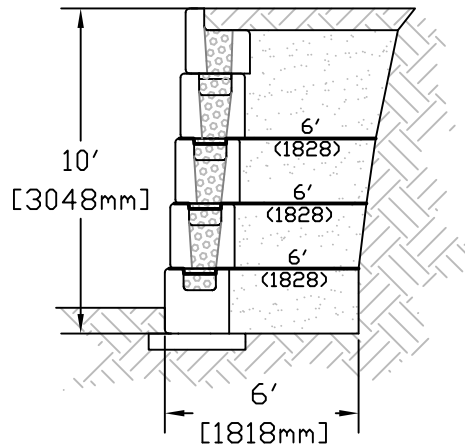
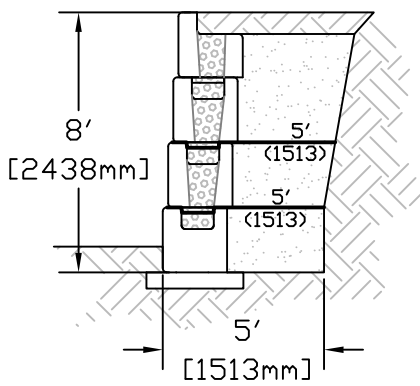
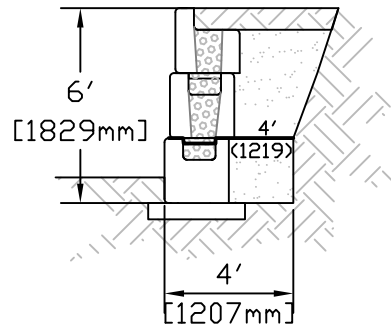

These preliminary details are intended solely to act as an aid when designing a wall. This drawing should not be used for final design or construction. Each site-specific wall should be certified and signed by a registered geotechnical engineer in the State or Province that it is being built. The accuracy and use of the details in this document are the sole responsibility of the user. Global stability analysis has not been performed.

The Trademark MagnumStone, Logo and Copyright are owned by CornerStone Wall Solutions, Inc. All Rights Reserved



MagnumStone®

26° | 250 PSF

Geogrid Wall Charts

Slope Angle	0°
Live Load	250 PSF
Retained Soil	26°
Foundation	26°
Reinforced	26°
Leveling Pad	Crushed Gravel

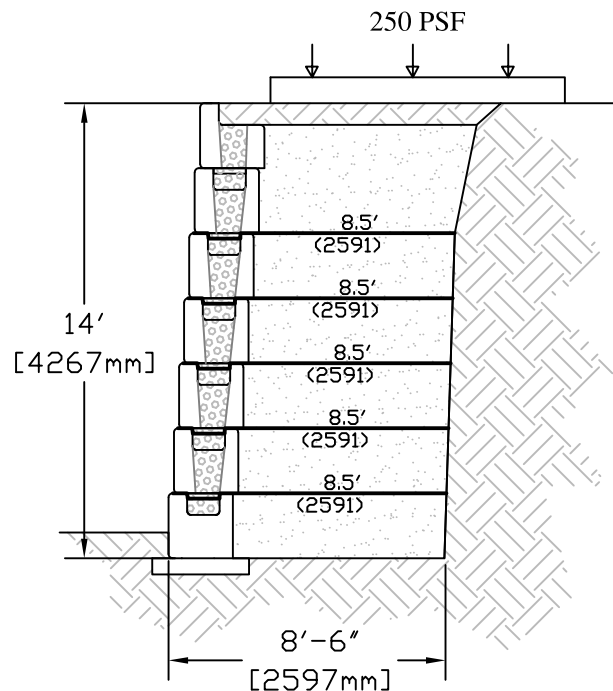
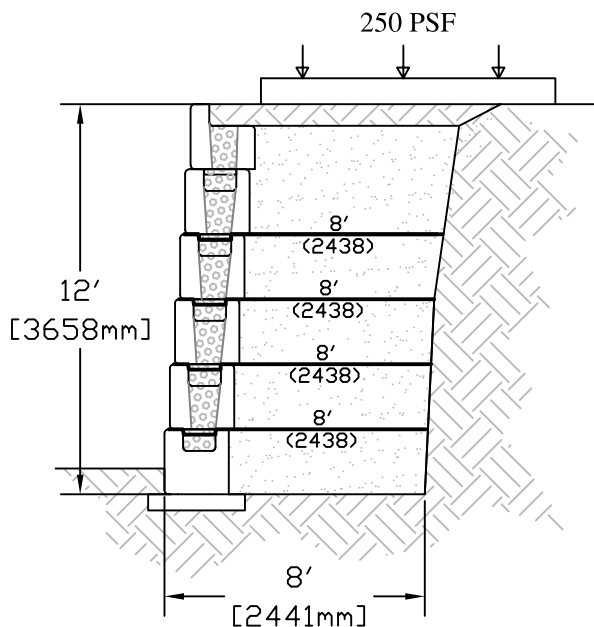
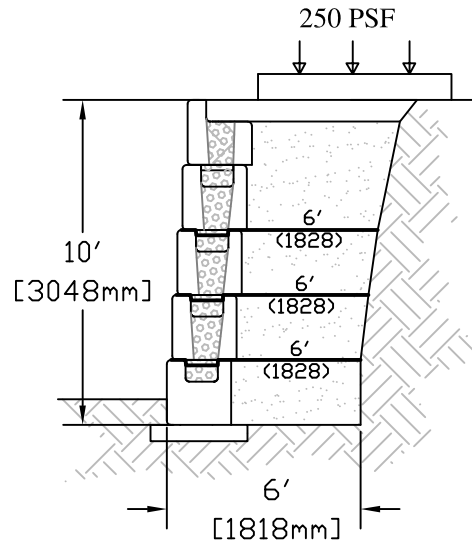
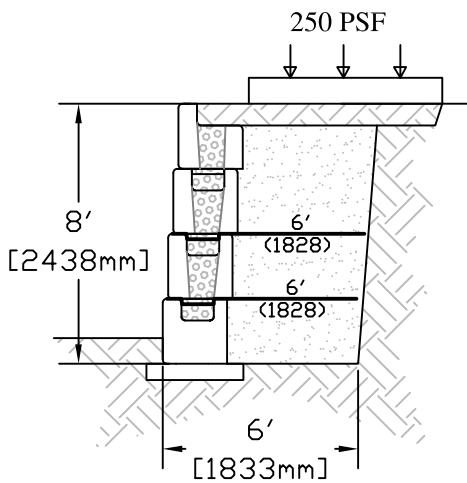
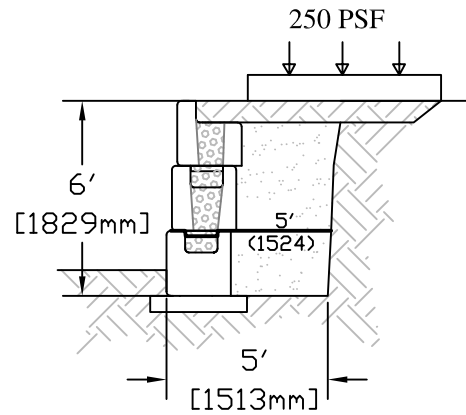

MagnumStone®

28° | 250 PSF

Geogrid Wall Charts

Slope Angle	0°
Live Load	250 PSF
Retained Soil	28°
Foundation	28°
Reinforced	28°
Leveling Pad	Crushed Gravel

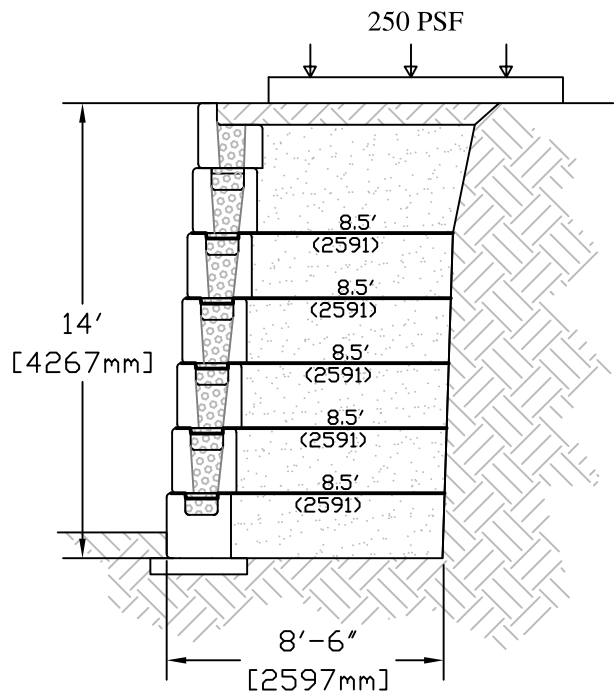
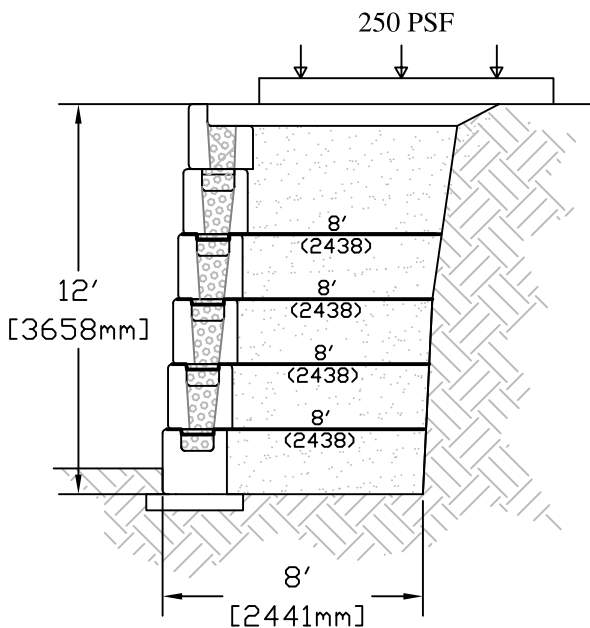
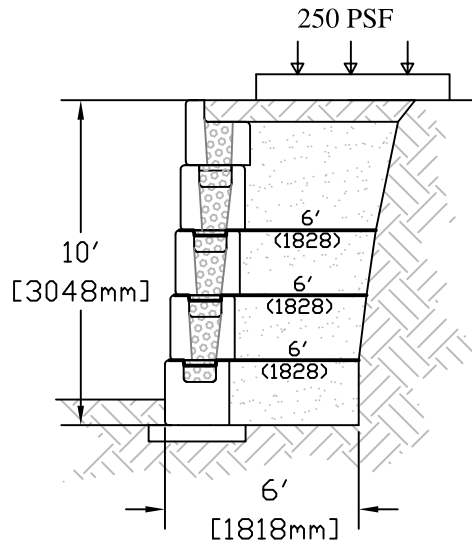
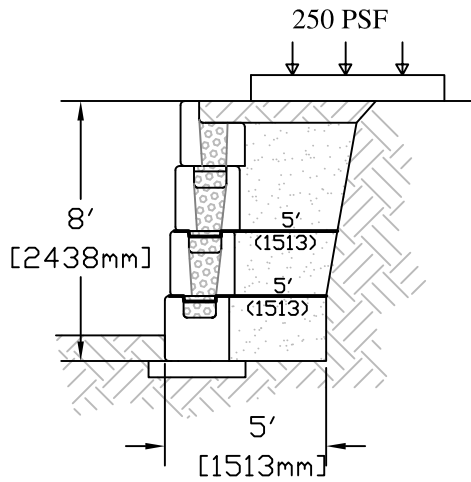
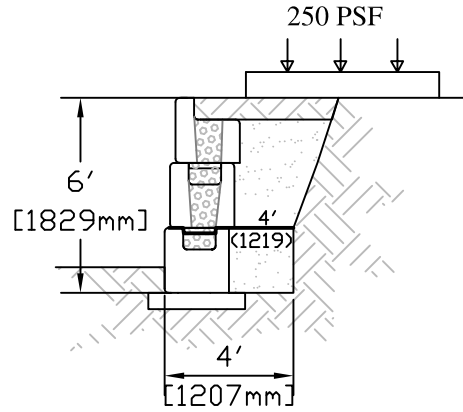

MagnumStone®

30° | 250 PSF

Geogrid Wall Charts

Slope Angle	0°
Live Load	250 PSF
Retained Soil	30°
Foundation	30°
Reinforced	30°
Leveling Pad	Crushed Gravel

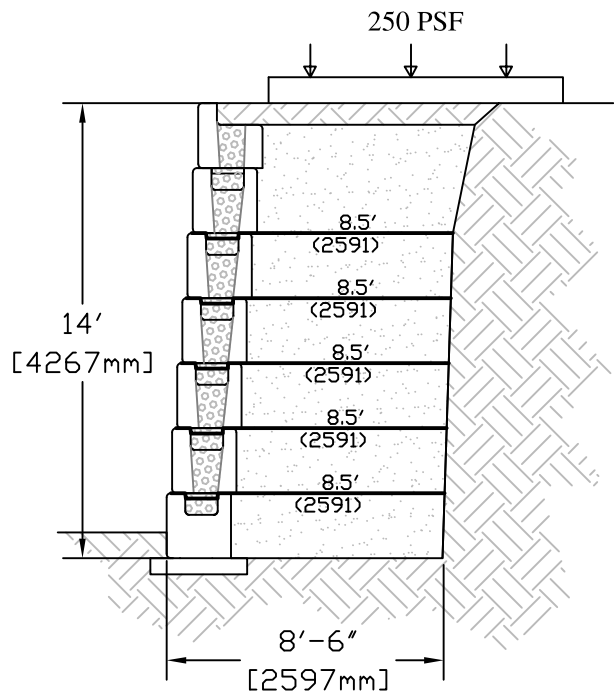
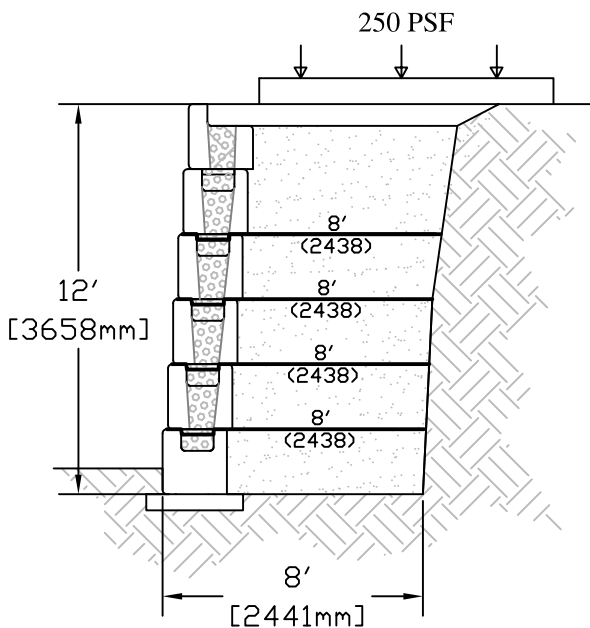
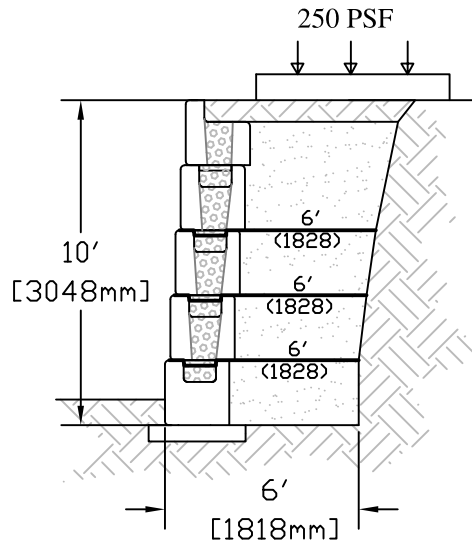
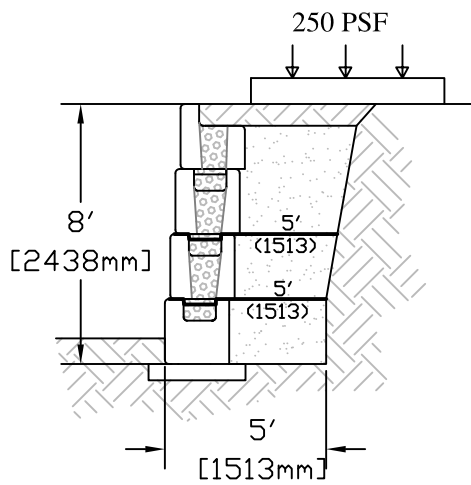
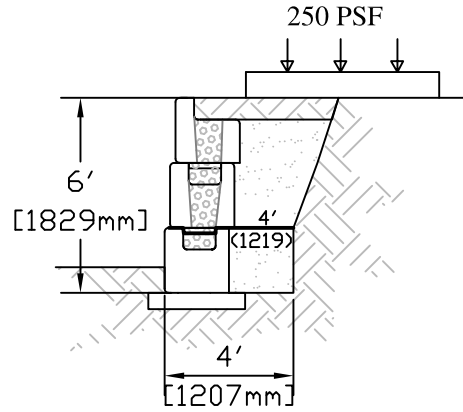

MagnumStone®

26° | 3:1 Slope

Geogrid Wall Charts

Slope Angle	18.4° 3:1
Live Load	0 PSF
Retained Soil	26°
Foundation	26°
Reinforced	26°
Leveling Pad	Crushed Gravel

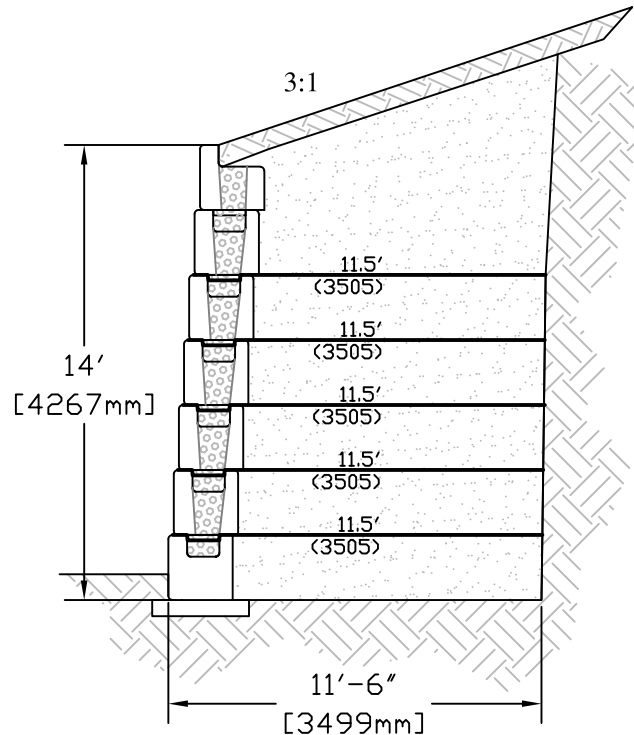
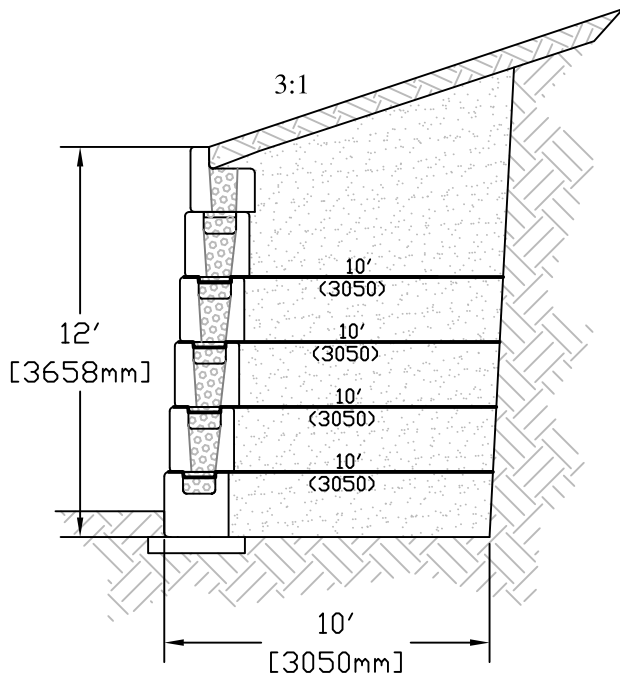
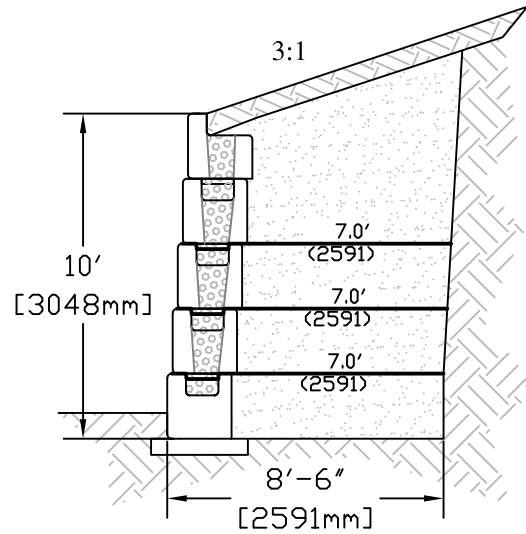
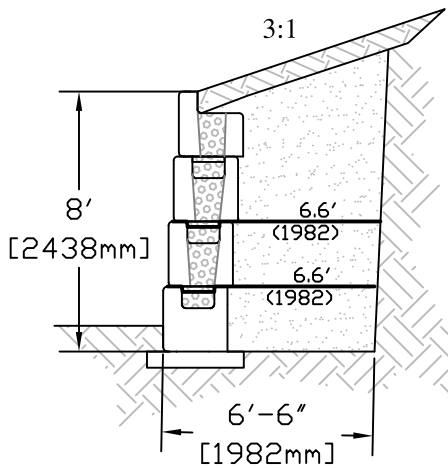
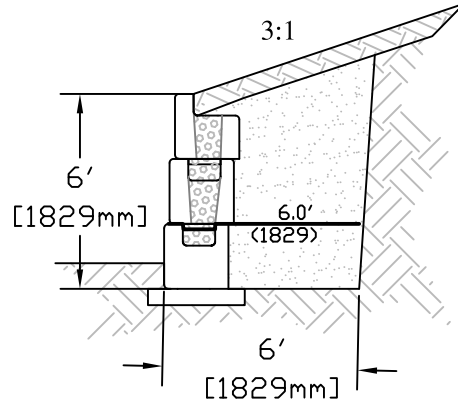

MagnumStone®

28° | 3:1 Slope

Geogrid Wall Charts

Slope Angle	18.4° 3:1
Live Load	0 PSF
Retained Soil	28°
Foundation	28°
Reinforced	28°
Leveling Pad	Crushed Gravel

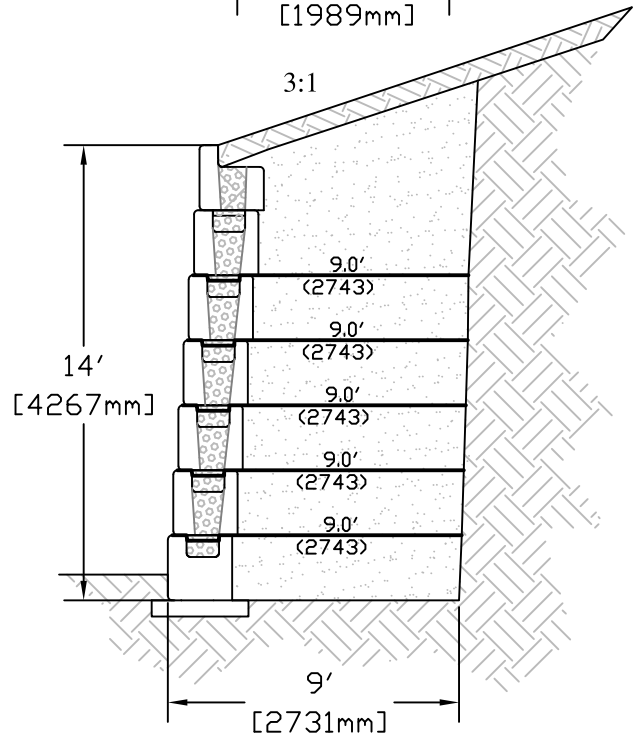
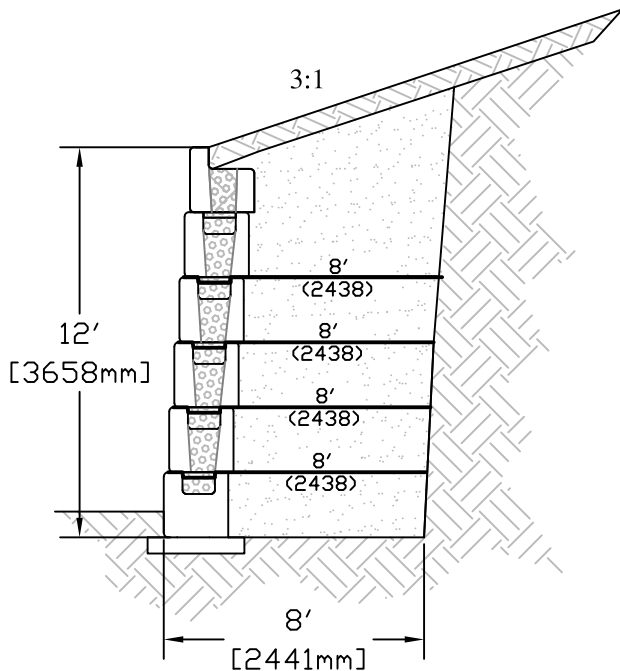
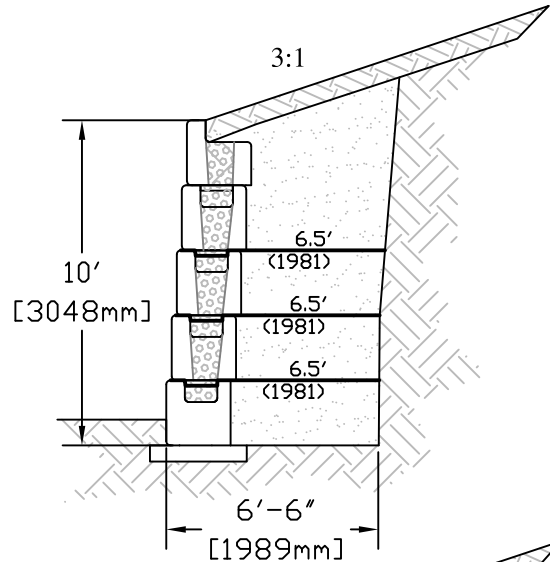
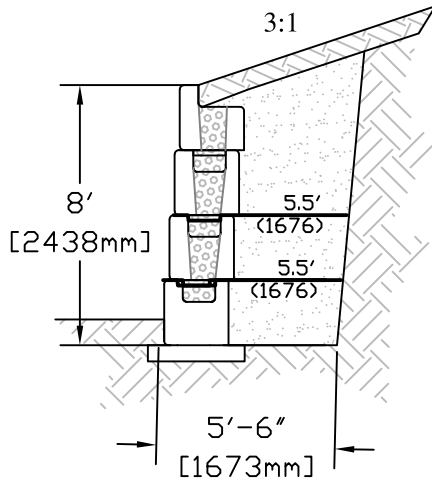
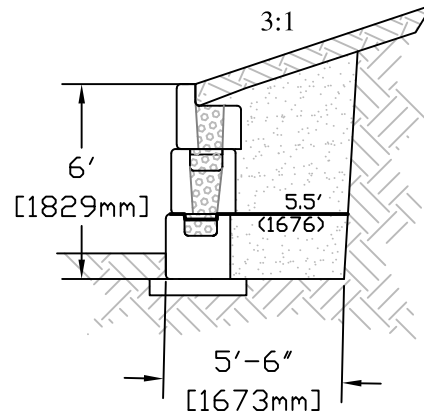

MagnumStone®

30° | 3:1 Slope

Geogrid Wall Charts

Slope Angle 18.4° 3:1
 Live Load 0 PSF
 Retained Soil 30°
 Foundation 30°
 Reinforced 30°
 Leveling Pad Crushed Gravel

